

FlexGun™ 3

Welding Guns

Ver. 1.3



CenterLine (Windsor) Limited

CENTERED ON SOLUTIONS

FlexGun™ 3

The FlexGun 3 welding guns have a robust construction and offer improved design flexibility to allow for future changes within the tool design or the product. The flexibility of the FlexGun 3 design allows for quick change of gun components and easy access for maintenance needs.

Key Advantages

- Identical modular gun base-body components for C and Pinch style guns.
- Common gun body for aluminum and steel applications.
- Range of 100 kVA to 225 kVA MFDC transformers (AC available on request).
- Heavy duty force capability with large throat geometries.
- Optimized part interchangeability between C and Pinch styles.
- Arm and adapter designs leverage existing standardized libraries to minimize types of arms and adapters. These features contribute to more convenient maintenance and spare part management.
- Integrated robot bracket.
- Total number of components reduced by 30% from the previous gun family.
- Wrought high-strength aluminum used as gun body material to enable high welding forces up to 16 kN.
- Servo and transformer are not structural components of gun body. If these components require service, they can be removed without taking apart the gun, which simplifies maintenance.
- 30 mm dual-guided rod design on C Gun contributes to less deflection under higher loads.

Key Features

- Weld force up to 10 kN C Gun, 16 kN Pinch Gun.
- Symmetrical bodies – no LH or RH versions.
- Same shunts are used on C Gun and Pinch Gun styles.
- Base models start at 100 kg.
- Aluminum arms have adaptive feedback connection points as standard.
- Four (4) integrated robot mounting options (included): LH, RH, Top, Bottom.
- Usable throats available up to 1200mm for Pinch Guns and 600 mm for C Guns.
- ISO "S" frame transformers, 100 kVA through 225 kVA MFDC (size 2 through 6).
- Optimized for use with roller screw servo actuator, 5 mm or 10 mm pitch.

Modular Components

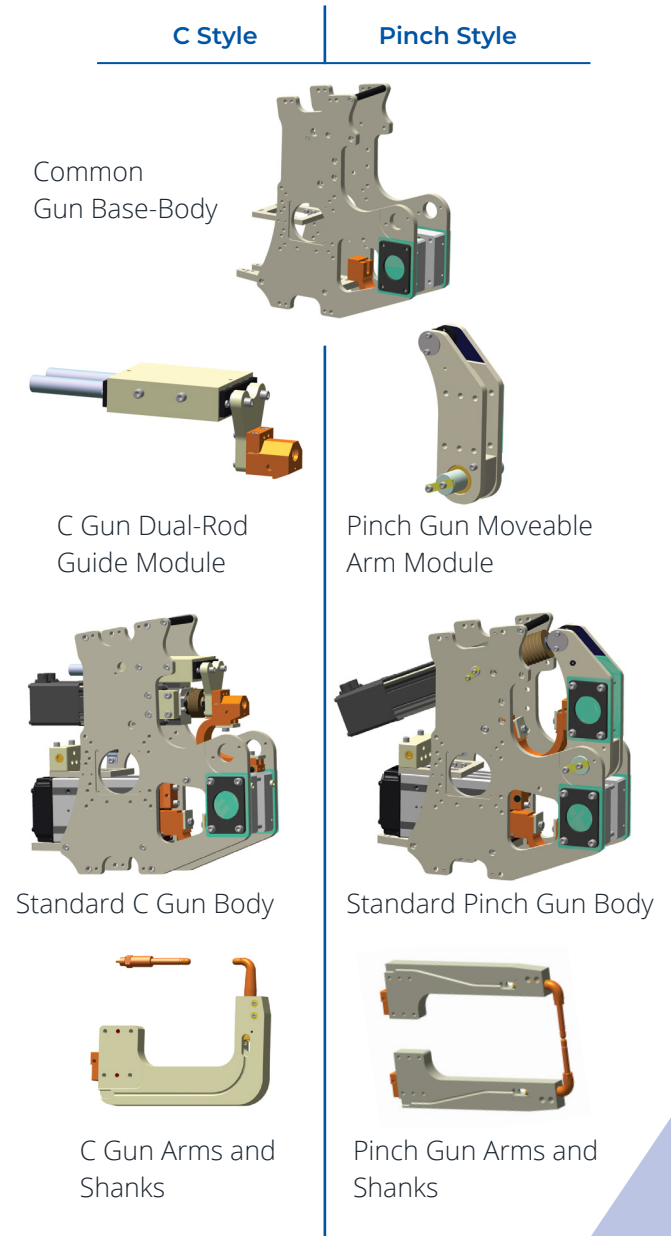

FlexGun™ 3 Configurations

A diverse range of FlexGun 3 welding guns are possible, based on the two main gun configurations illustrated below.

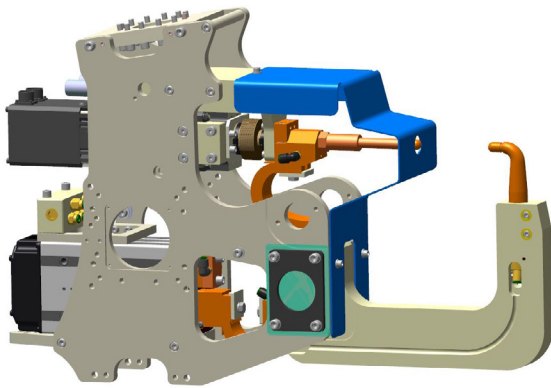

C Style

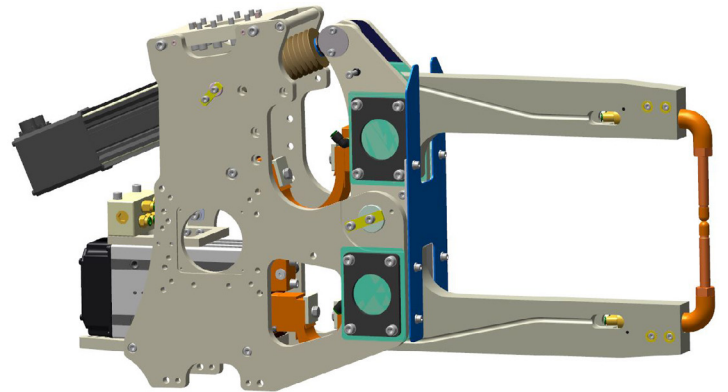

Pinch Style

FlexGun 3 Gun Weight (Approximate)									
Welding Application				Steel		Steel/Aluminum		Aluminum	
Transformer kVA				100		170		200	
Gun Style	Gun Size	Gun Throat	Gun Throat	Weight		Weight		Weight	
		Depth (mm)	Height (mm)						
				lbs	kg	lbs	kg	lbs	kg
C Style	Small	100	60	220	100	249	113	304	138
	Medium	200	200	227	103	255	116	310	141
	Large	400	355	235	107	264	120	319	145
	Extra Large	500	555	249	113	277	126	332	151
Pinch Style	Small	300	50	229	104	246	112	301	137
	Medium	400	150	238	108	255	116	310	141
	Large	500	250	246	112	264	120	319	145
	Extra Large	600	300	260	118	275	125	330	150

Robot Mounting Locations

A Robot Bracket is included for use in mounting the FlexGun 3 to a robot, up to four (4) mounting locations and/or orientations are possible.

NOTE: Only one robot bracket for the integrated mounting locations is included. Additional cost for rear mount bracket.

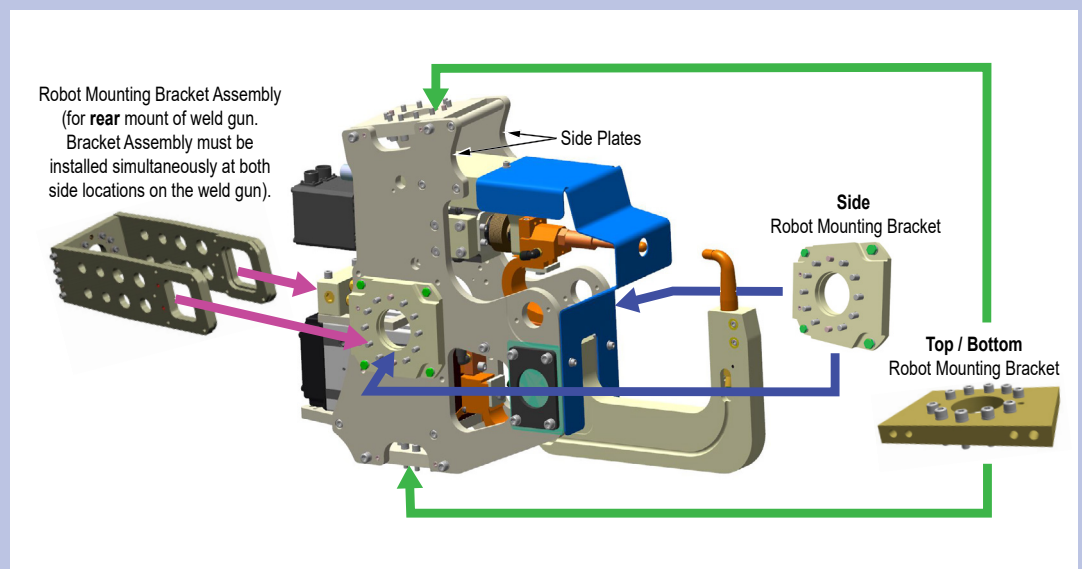

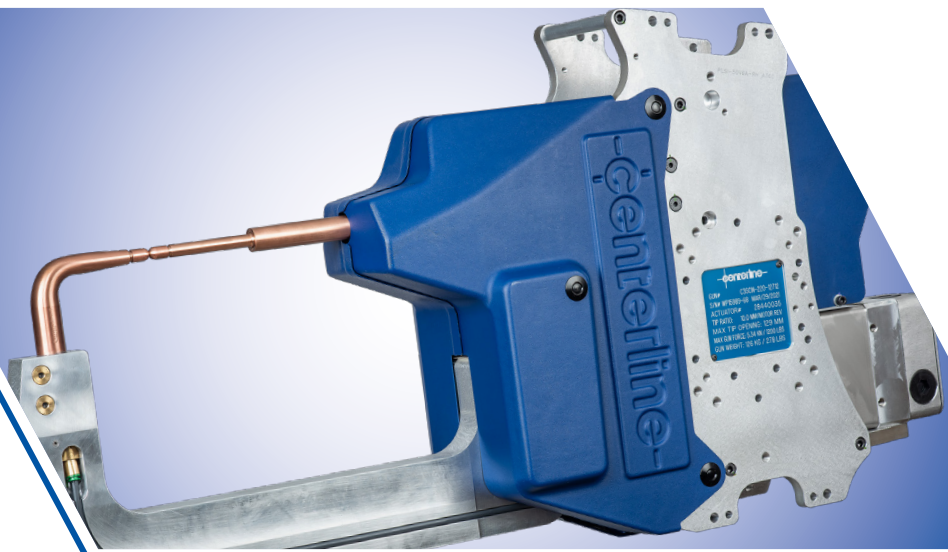

CenterLine (Windsor) Limited
CENTERED ON SOLUTIONS

CONTACT US

www.cntrline.com



Platinum member



415 Morton Dr.
Windsor ON
N9J 3T8



Telephone:
+1 519-734-8464
Fax:
+1 519-734-2000



E-mail:
info@cntrline.com